

William Modular

Page 1 of 2

AUSTRALIAN DESIGNED AND MANUFACTURED

ESTABLISHED 1979



arthur**G**

William 3S Modular

William Modular

Page 2 of 2

Dimensions

2.5 Seater LHF with corner
2.5 Seater RHF with one arm

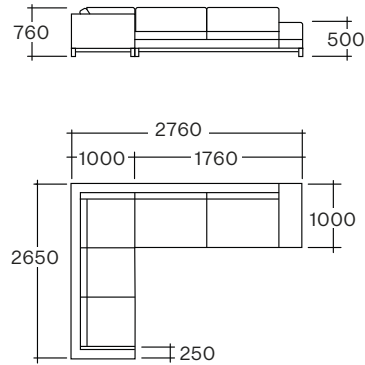

3 Seater LHF with corner
3 Seater RHF with one arm

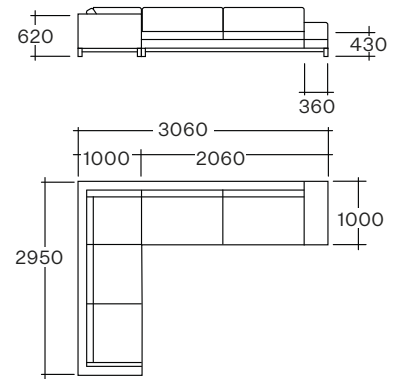

3.5 Seater LHF with corner
3.5 Seater RHF with one arm

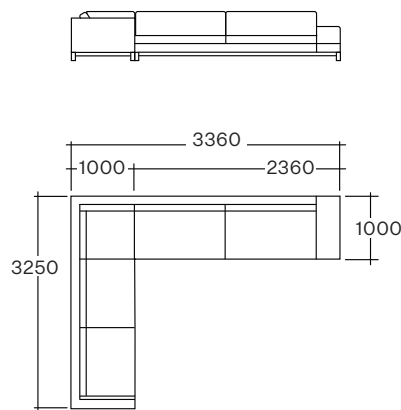

4 Seater LHF with corner
4 Seater RHF with one arm

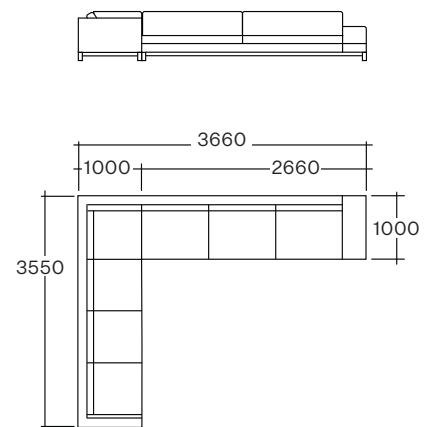

Alternative sizes and configurations available.

Specifications

Materials

Solid hardwood

Cushioning

High density premium foam with dacron wrap or feather wrap

Upholstery

Fabric, leather

Leg

Victorian Ash Rail, American Oak Rail

Leg Stain

8 finishes

Options

Two high angled arms, two low arms, or as pictured. Matching ottoman available

Guarantee

10 year structural guarantee

GECA certified manufacturer



arthurG

arthurg.com.au
sales@arthurg.com.au

Factory

1 Stafford St
Huntingdale
VIC 3166
+61 3 9543 4633

Melbourne

618 Church St
Richmond
VIC 3121
+61 3 9429 6696

Sydney

1/8 Hill St
Surry Hills
NSW 2010
+61 2 9332 1488

Perth

207 Stirling Hwy
Claremont
WA 6010
+61 8 9286 1433

Brisbane

977A Ann St
Fortitude Valley
QLD 4006
T +61 7 3924 7913

Transforma

21 Kensington Rd
Norwood
SA 5067
+61 8 8332 4044